

NOTES: UNLESS OTHERWISE SPECIFIED
THIS IS A CAD GENERATED DRAWING, DO NOT REVISE MANUALLY

REVISION HISTORY					
ZONE	REV	DESCRIPTION	E.C.O.NO	DATE	APPROVED
	1	ENGINEERING RELEASE			

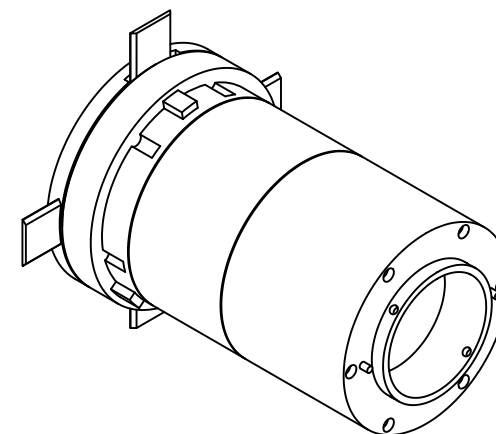
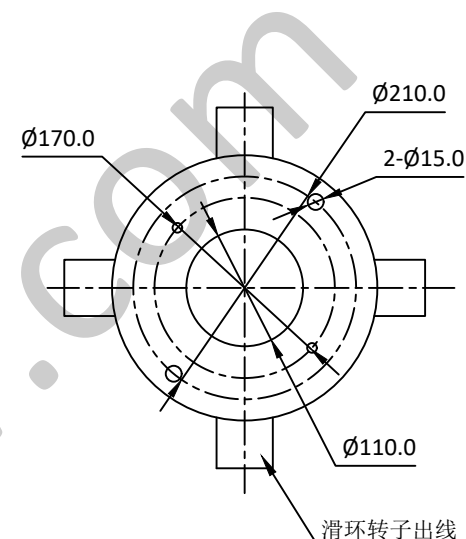
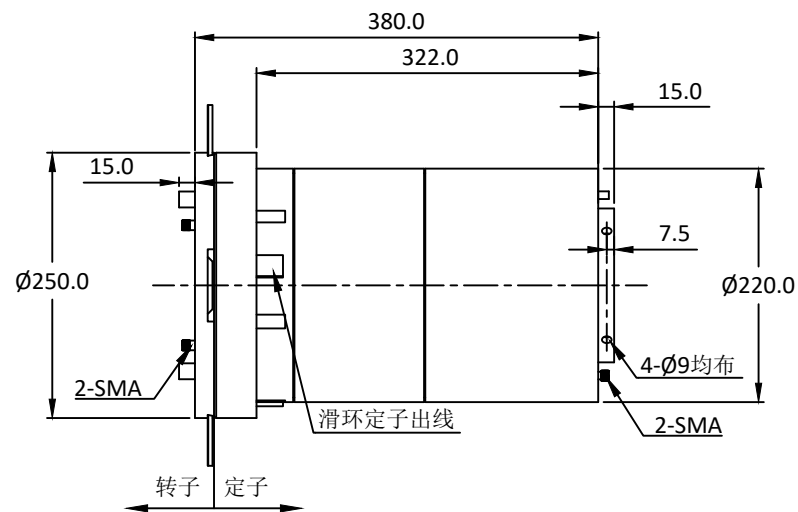

LRJ-1117

—电气技术参数Electrical Specifications—

通道Channel:	CH1	CH2
工作频率 Frequency Range:	1.35GHz ±50MHz	1.59GHz±20MHz
插入损耗Insertion Loss:	1dB(Max)	1dB(Max)
插入损耗最大波动值:	0.1dB	0.15dB
电压驻波比VSWR:	1.6(Max)	1.6(Max)
驻波比最大波动值:	0.2	0.2
耐功率Power:	30W(CW)	30W(CW)
工作温度Operation Temperature:	-30~+65°C	
存储温度Storage Temperature:	-45~+75°C	
转动速度Speed:	30rpm(Max)	
寿命Life:	2*10 ⁶ 转(Min)	

—机械技术参数Mechanical Specification—

接口Connectors:	SMA-F	SMA-F
样式Type:	/	/
重量Weight:	/	/

UNLESS OTHERWISE SPECIFIED
DIMENSIONS ARE MILLIMETER
TOLERANCES ARE:
DECIMALS ANGLES FRACTIONS
.XX±0.1 ±1' ±2/5
.XXX±0.03
.XXX±0.012

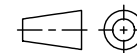

Approvals

DATE

DRWN

ENG

CHK

Q.A.



www.lairmw.com sales@lairmw.com

P/N: LRJ-1117

双通道同轴旋转关节+电滑环

SIZE
A3

CAGE NO

DWG NO.

REV
1

SCALE
3:2

UNIT
mm

SHEET 1 OF 1

HOLE DIAMETER
.35 TO 3.20
3.21 TO 6.35
6.36 TO 12.70
12.71 TO 19.05
19.06 TO 25.40
25.41 TO 50.80

TOLERANCES
+05/-02
+10/-03
+15/-03
+20/-03
+25/-03
+30/-03