

NOTES: UNLESS OTHERWISE SPECIFIED  
THIS IS A CAD GENERATED DRAWING, DO NOT REVISE MANUALLY

REVISION HISTORY					
ZONE	REV	DESCRIPTION	E.C.O.NO	DATE	APPROVED
	1	ENGINEERING RELEASE			

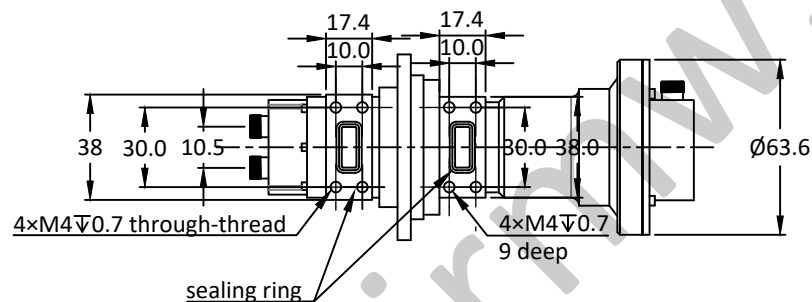
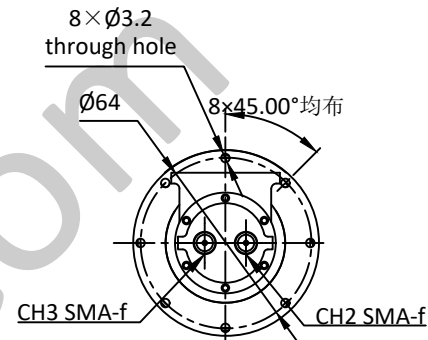
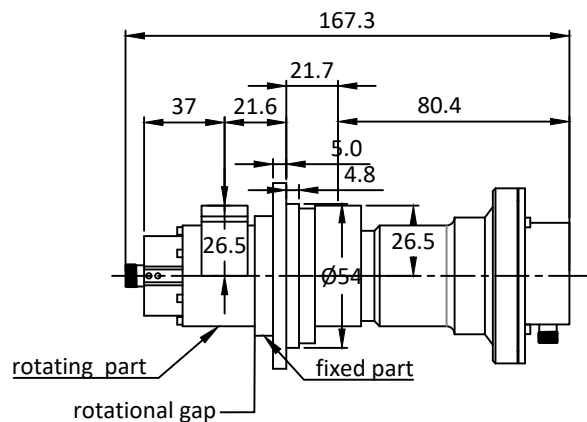
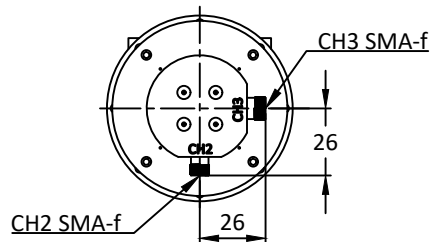

## LRJ-1102

波导同轴三通道旋转关节 Rotary Joint  
—电气技术参数 Electrical Specifications—

通道 Channel:	CH1	CH2	CH3
工作频率 Frequency Range:	13.75 - 14.5GHz	DC - 12.75GHz	DC - 5GHz
插入损耗 Insertion Loss:	0.5dB@13.75-14GHz(Max) 0.2dB@14-14.5GHz(Max)	1.0dB@DC-6.0GHz(Max) 1.5dB@6.0-12.75GHz(Max)	1.0dB(Max)
插入损耗最大波动值:	0.05dB	0.06dB	0.1dB
电压驻波比 VSWR:	1.3@13.75-14GHz(Max) 1.2@14-14.5GHz(Max)	1.6(Max)	1.6(Max)
驻波比最大波动值:	0.1	0.1	0.5
耐功率 Power:	450W(CW) 2kW(Peak)	25W@DC-2.0GHz(CW) 17W@2.0-4.0GHz(CW) 12W@4.0-8.0GHz(CW)	10W(CW) 1kW(Peak)
工作温度 Operation Temperature:	-40~+70°C		
存储温度 Storage Temperature:	-55~+85°C		
转动速度 Speed:	60rpm(Max)		
寿命 Life:	5*10 <sup>6</sup> 转(Min)		

—机械技术参数 Mechanical Specification—

接口 Connectors:	R120@CH1	SMA-F@CH2&3
样式 Type:	U	L
重量 Weight:	600g	

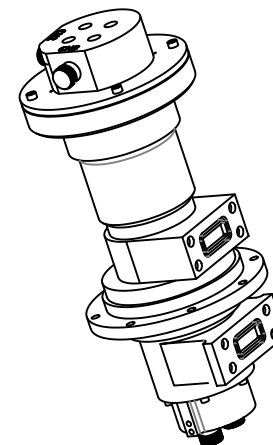

UNLESS OTHERWISE SPECIFIED DIMENSIONS ARE MILLIMETER TOLERANCES ARE: DECIMALS ANGLES FRACTIONS .X±0.1 ±1' ±2/5 .XX±0.03 .XXX±0.012						P/N: LRJ-1102											
HOLE DIAMETER .35 TO 3.20 3.21 TO 6.35 6.36 TO 12.70 12.71 TO 19.05 19.06 TO 25.40 25.41 TO 50.80		TOLERANCES +05/-02 +10/-03 +15/-03 +20/-03 +25/-03 +30/-03		<table border="1"> <tr> <td>Approvals</td> <td>DATE</td> </tr> <tr> <td>DRWN</td> <td></td> </tr> <tr> <td>ENG</td> <td></td> </tr> <tr> <td>CHK</td> <td></td> </tr> <tr> <td>Q.A.</td> <td></td> </tr> </table>		Approvals	DATE	DRWN		ENG		CHK		Q.A.		www.lairmw.com sales@lairmw.com	
Approvals	DATE																
DRWN																	
ENG																	
CHK																	
Q.A.																	
3 CHANNEL WAVEGUIDE ROTARY JOINT 波导同轴—三通道旋转关节																	
SIZE A3		CAGE NO		DWG NO.		REV 1											
SCALE 3:2		UNIT mm		SHEET 1 OF 1													