

NOTES: UNLESS OTHERWISE SPECIFIED  
THIS IS A CAD GENERATED DRAWING, DO NOT REVISE MANUALLY

REVISION HISTORY					
ZONE	REV	DESCRIPTION	E.C.O.NO	DATE	APPROVED
	1	ENGINEERING RELEASE			

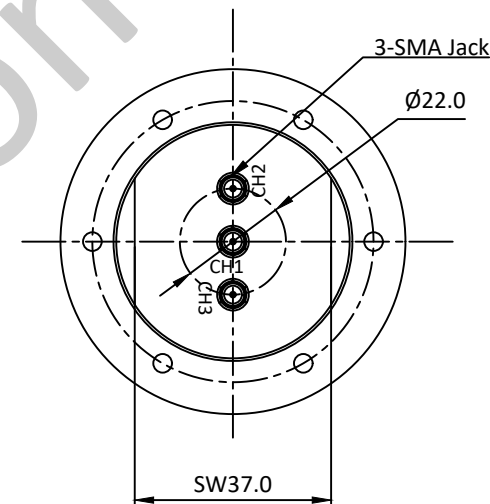
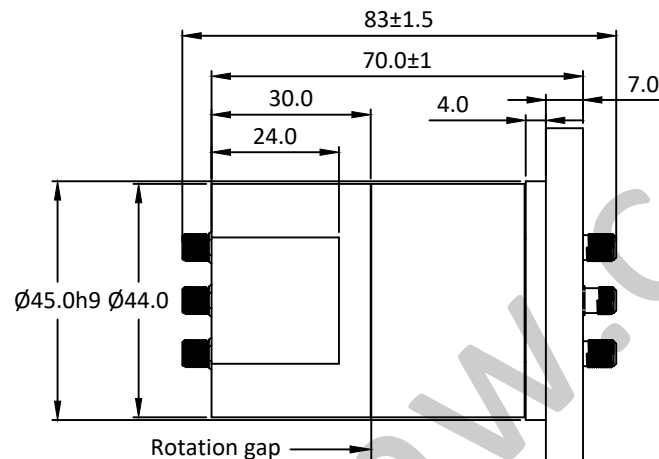
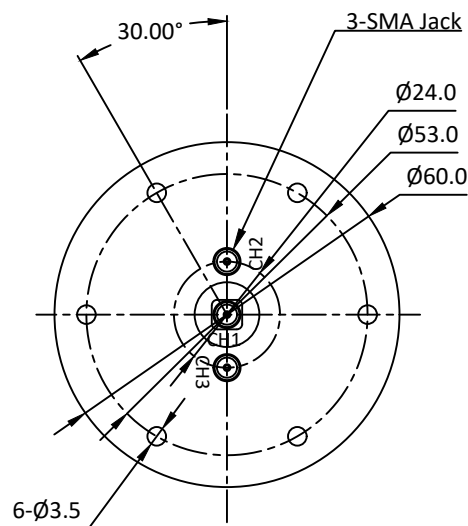

## LRJ-1047

3通道同轴旋转关节 Three Channel Coax Rotary Joint  
—电气技术参数 Electrical Specifications—

通道 Channel:	CH1	CH2	CH3
工作频率 Frequency Range:	6 - 8GHz	0.1 - 0.6GHz	1 - 3GHz
插入损耗 Insertion Loss:	1.5dB(Max)	0.5dB(Max)	1dB(Max)
插入损耗最大波动值:	0.1dB	0.1dB	0.1dB
电压驻波比 VSWR:	2(Max)	1.3(Max)	1.5(Max)
驻波比最大波动值:	0.1	0.1	0.1
耐功率 Power:	10W(CW)	10W(CW)	10W(CW)
工作温度 Operation Temperature:	-50~+85°C		
存储温度 Storage Temperature:	-55~+85°C		
转动速度 Speed:	60rpm(Max)		
寿命 Life:	5*10 <sup>6</sup> 转(Min)		

—机械技术参数 Mechanical Specification—

接口 Connectors:	SMA-F(50Ω)@CH1&2&3
样式 Type:	/
重量 Weight:	260g

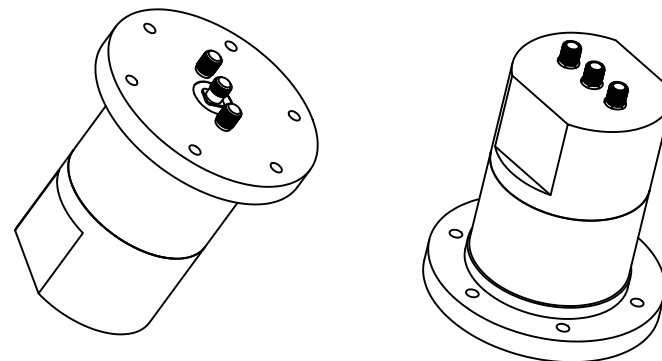

UNLESS OTHERWISE SPECIFIED DIMENSIONS ARE MILLIMETER TOLERANCES ARE: DECIMALS ANGLES FRACTIONS .X±0.1 ±1' ±2/5 .XX±0.03 .XXX±0.012						P/N: LRJ-1047											
HOLE DIAMETER .35 TO 3.20 3.21 TO 6.35 6.36 TO 12.70 12.71 TO 19.05 19.06 TO 25.40 25.41 TO 50.80		TOLERANCES +.05/-0.2 +.10/-0.3 +.15/-0.3 +.20/-0.3 +.25/-0.3 +.30/-0.3		<table border="1"> <tr> <td>Approvals</td> <td>DATE</td> </tr> <tr> <td>DRWN</td> <td></td> </tr> <tr> <td>ENG</td> <td></td> </tr> <tr> <td>CHK</td> <td></td> </tr> <tr> <td>Q.A.</td> <td></td> </tr> </table>		Approvals	DATE	DRWN		ENG		CHK		Q.A.		<p>THREE CHANNEL COAX ROTARY JOINT 3通道同轴旋转关节</p>	
Approvals	DATE																
DRWN																	
ENG																	
CHK																	
Q.A.																	
SIZE A3		CAGE NO		DWG NO.		REV 1											
SCALE 3:2		UNIT mm		SHEET 1 OF 1													