

NOTES: UNLESS OTHERWISE SPECIFIED
THIS IS A CAD GENERATED DRAWING, DO NOT REVISE MANUALLY

REVISION HISTORY					
ZONE	REV	DESCRIPTION	E.C.O.NO	DATE	APPROVED
	1	ENGINEERING RELEASE			

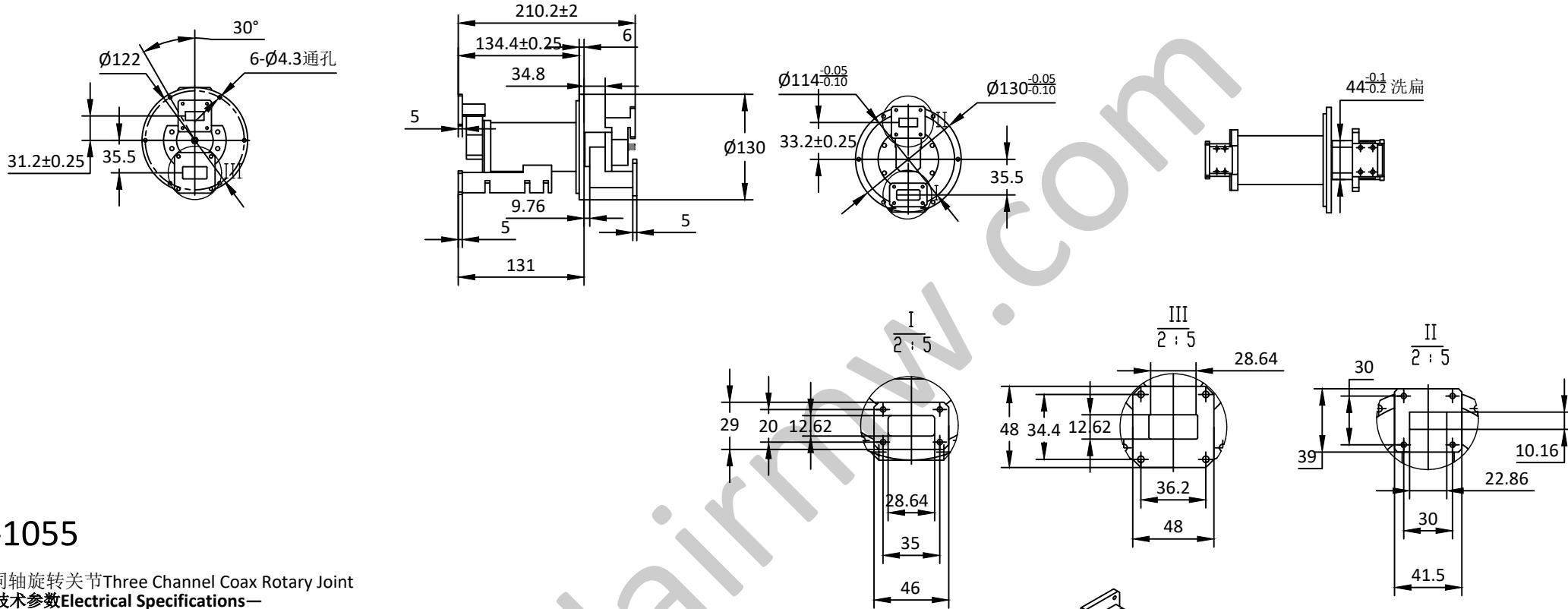

LRJ-1055

3通道同轴旋转关节 Three Channel Coax Rotary Joint

—电气技术参数 Electrical Specifications—

通道 Channel:	CH1	CH2	CH3
工作频率 Frequency Range:	8.5 - 9.5GHz	8.5- 9.5GHz	DC- 8GHz
插入损耗 Insertion Loss:	0.3dB(Max)	1.0dB(Max)	1.0dB(Max)
插入损耗最大波动值:	0.1dB	0.1dB	0.1dB
电压驻波比 VSWR:	1.3(Max)	1.5(Max)	1.75(Max)
驻波比最大波动值:	0.1	0.1	0.1
耐功率 Power:	360W(CW) 12kW(Peak)	10W(CW) 500W(Peak)	10W(CW) 1kW(Peak)
工作温度 Operation Temperature:	-40~+70°C		
存储温度 Storage Temperature:	-55~+85°C		
转动速度 Speed:	30rpm(Max)		
寿命 Life:	5*10 ⁶ 转(Min)		

—机械技术参数 Mechanical Specification—

接口 Connectors:	BJ84	BJ100	SMA
样式 Type:	/		
重量 Weight:	350g		

UNLESS OTHERWISE SPECIFIED
DIMENSIONS ARE MILLIMETER
TOLERANCES ARE:
DECIMALS ANGLES FRACTIONS
.XX±0.1 ±1' ±2/5
.XXX±0.03
.XXX±0.012

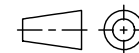

Approvals

DATE

DRWN

ENG

CHK

Q.A.

HOLE DIAMETER
.35 TO 3.20
3.21 TO 6.35
6.36 TO 12.70
12.71 TO 19.05
19.06 TO 25.40
25.41 TO 50.80

TOLERANCES
+05/-02
+10/-03
+15/-03
+20/-03
+25/-03
+30/-03



www.lairmw.com sales@lairmw.com

P/N: LRJ-1055

THREE CHANNEL COAX ROTARY JOINT
3通道同轴旋转关节

SIZE	CAGE NO	DWG NO.	REV
A3			1
SCALE	UNIT	SHEET 1 OF 1	
3:2	mm		