

NOTES: UNLESS OTHERWISE SPECIFIED  
THIS IS A CAD GENERATED DRAWING, DO NOT REVISE MANUALLY

REVISION HISTORY					
ZONE	REV	DESCRIPTION	E.C.O.NO	DATE	APPROVED
	1	ENGINEERING RELEASE			

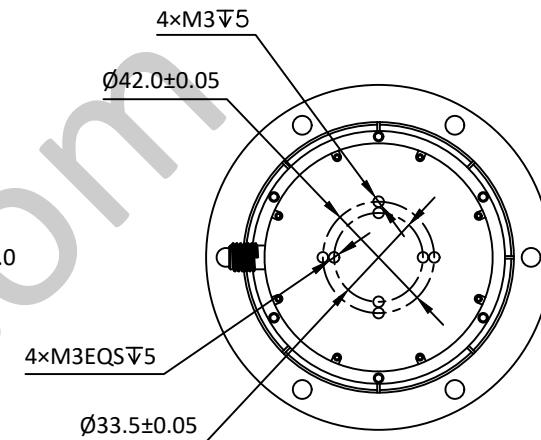
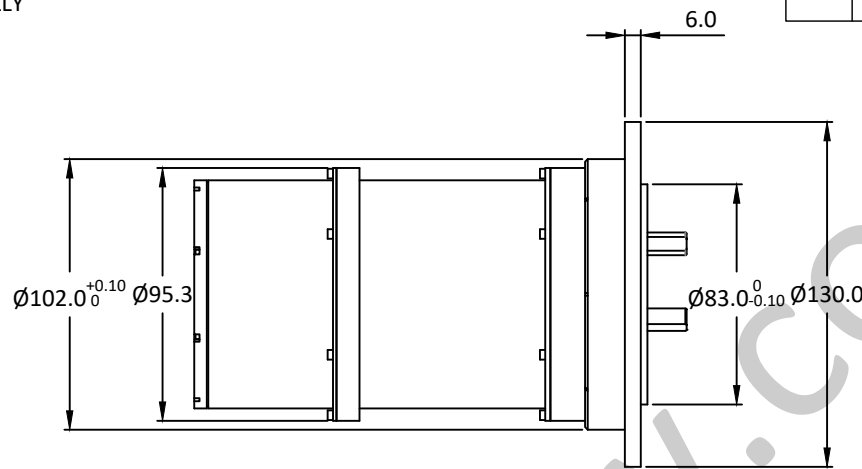
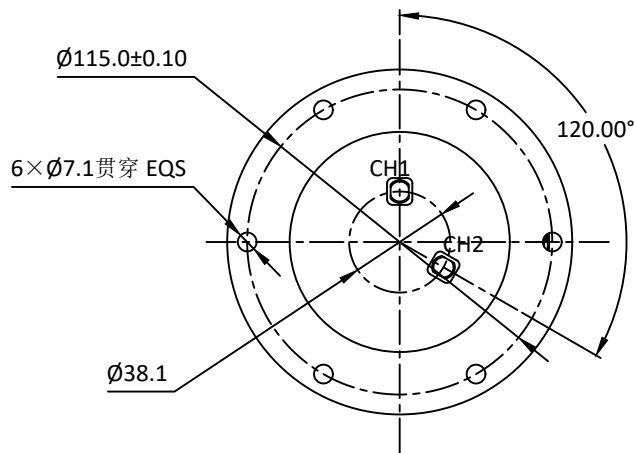

## LRJ-1025

双通道旋转关节 Dual Channel Rotary Joint  
—电气技术参数 Electrical Specifications—

通道 Channel:	CH1	CH2
工作频率 Frequency Range:	1.0 - 1.3GHz	1.0 - 1.3GHz
插入损耗 Insertion Loss:	0.8dB(Max)	0.8dB(Max)
插入损耗最大波动值:	0.1dB	0.1dB
电压驻波比 VSWR:	1.5(Max)	1.5(Max)
驻波比最大波动值:	0.1	0.1
隔离度 Isolation:		60dB
耐功率 Power:	500W(CW) 1kW(Peak)	500W(CW) 1kW(Peak)

工作温度 Operation Temperature:	-40~+70°C	
存储温度 Storage Temperature:	-55~+85°C	
转动速度 Speed:		120rpm(Min)
寿命 Life:		1亿转

—机械技术参数 Mechanical Specification—

接口 Connectors:	N-F
样式 Type:	/
重量 Weight:	3.0kg

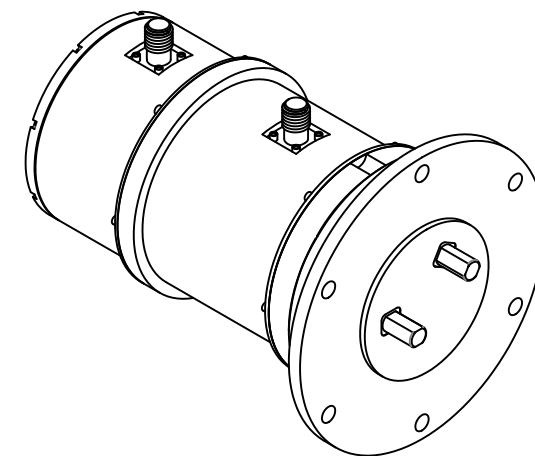
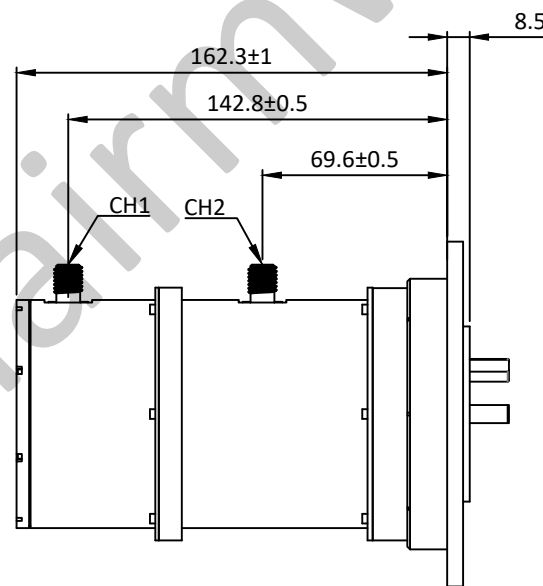

UNLESS OTHERWISE SPECIFIED  
DIMENSIONS ARE MILLIMETER  
TOLERANCES ARE:  
DECIMALS ANGLES FRACTIONS  
.X±0.1 ±1' ±2/5  
.XX±0.03  
.XXX±0.012

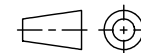

Approvals	DATE
DRWN	
ENG	
CHK	
Q.A.	

**莱尔微波**  
Laird Microwave

www.lairmw.com sales@lairmw.com

P/N: LRJ-1025

DUAL CHANNEL ROTARY JOINT  
双通道旋转关节

SIZE	CAGE NO	DWG NO.	REV
A3			1
SCALE	UNIT	SHEET 1 OF 1	
3:2	mm		