

NOTES:UNLESS OTHERWISE SPECIFIED
THIS IS A CAD GENERATED DRAWING,DO NOT REVISE MANUALLY

| REVISION HISTORY | | | | | |
|------------------|-----|---------------------|----------|------|----------|
| ZONE | REV | DESCRIPTION | E.C.O.NO | DATE | APPROVED |
| | 1 | ENGINEERING RELEASE | | | |

LSN-2011

20 – 50 GHz 功分/合路器 Power Splitter/Combiner

—电气技术参数 Electrical Specifications—

| | |
|-----------------------------|--------------|
| 频率范围 Frequency Range: | 20 – 50GHz |
| 隔离度 Isolation: | 20dB |
| 插入损耗 Insertion Loss: | 2.5dB |
| 相位平衡 Phase Balance: | ±5° |
| 幅度平衡 Amplitude Balance: | ±0.4dB |
| 输入驻波比 Input VSWR: | 1.4:1 |
| 输出驻波比 Output VSWR: | 1.4:1 |
| 最大输入功率 Maximum Input Power: | 43dBm |
| 工作温度 Operation Temperature: | -40 ~ +85°C |
| 存储温度 Storage Temperature: | -65 ~ +125°C |

—机械技术参数 Mechanical Specifications—

| | |
|---------------------------------|------------|
| 输入连接器 Input Interface: | 2.4mm-F |
| 输出连接器 Output Interface: | 2.4mm-F |
| 尺寸 Size(excluding connectors) : | 19x26x11mm |
| 重量 Weight: | 18.6g |

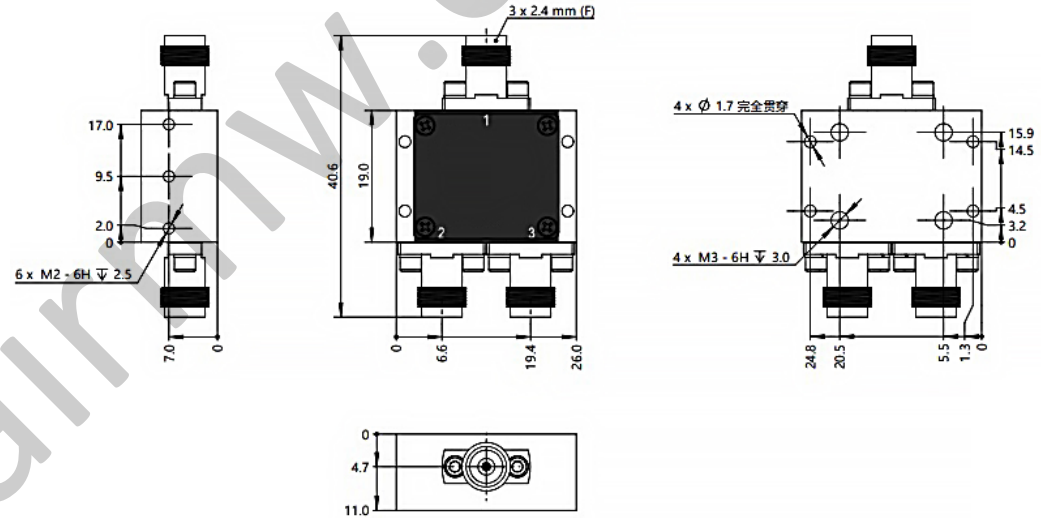

| | | | | | | |
|--|--|--------------|--|--|---------|-----|
| UNLESS OTHERWISE SPECIFIED DIMENSIONS ARE MILLIMETER TOLERANCES ARE: DECIMALS ANGLES FRACTIONS .XX±0.03 ±1' ±2/5 .XXX±0.012 | | | 莱尔微波 Laird Microwave www.lairmw.com sales@lairmw.com | P/N: LSN-2011 | | |
| | Approvals | DATE | | 20 - 50 GHz Power Splitter/Combiner | | |
| HOLE DIAMETER .35 TO 3.20 3.21 TO 6.35 6.36 TO 12.70 12.71 TO 19.05 19.06 TO 25.40 25.41 TO 50.80 | TOLERANCES +.05/- .02 +.10/- .03 +.15/- .03 +.20/- .03 +.25/- .03 +.30/- .03 | DRWN | | | | |
| | | ENG | | | | |
| | | CHK | | | | |
| | | Q.A. | | | | |
| | | SIZE | A3 | CAGE NO | DWG NO. | REV |
| | | SCALE | 3:2 | UNIT | mm | 1 |
| | | SHEET 1 OF 1 | | | | |