

NOTES:UNLESS OTHERWISE SPECIFIED  
THIS IS A CAD GENERATED DRAWING,DO NOT REVISE MANUALLY

REVISION HISTORY					
ZONE	REV	DESCRIPTION	E.C.O.NO	DATE	APPROVED
	1	ENGINEERING RELEASE			

## LPD2N-DC-6

DC – 6000 MHz 电阻功分器 Resistor Power Divider

### —电气技术参数 Electrical Specifications—

频率范围 Frequency Range:	DC – 6000 MHz
隔离度 Isolation:	5.6dB(Min.)
插入损耗 Insertion Loss:	≤6.8dB
相位平衡 Phase Balance:	±3°
幅度平衡 Amplitude Balance:	≤0.3dB
输入驻波比 Input VSWR:	1.18(Typ.)/1.3(Max.)
输出驻波比 Output VSWR:	1.18(Typ.)/1.3(Max.)
承受功率 Power Rating:	2W
工作温度 Operation Temperature:	-35 ~ +75°C

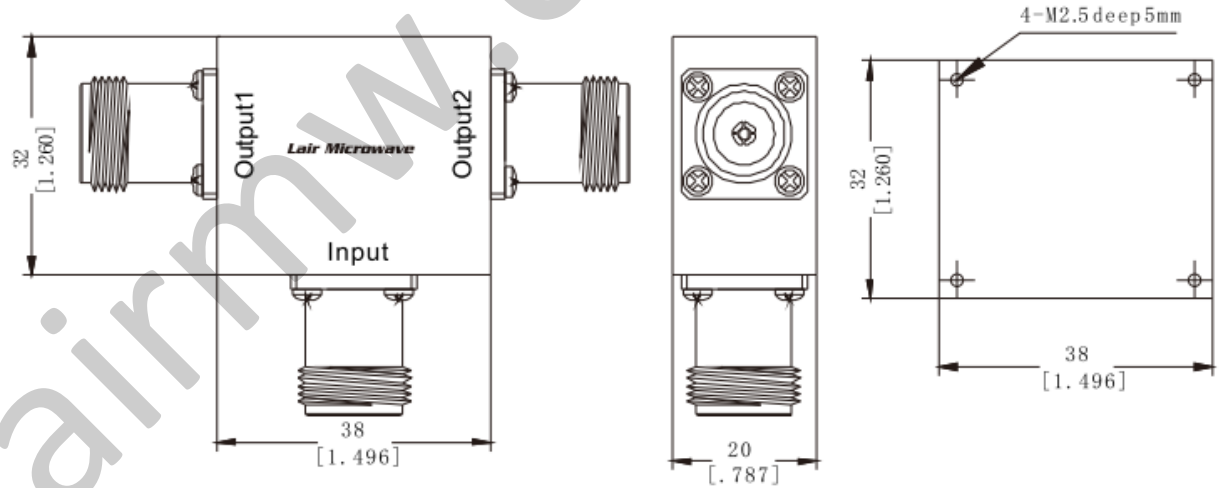

### —机械技术参数 Mechanical Specifications—

输入连接器 Input Interface:	N-F
输出连接器 Output Interface:	N-F
尺寸 Size (excluding connectors):	38*32*20mm
重量 Weight:	160g

UNLESS OTHERWISE SPECIFIED DIMENSIONS ARE MILLIMETER TOLERANCES ARE: DECIMALS ANGLES FRACTIONS .XX±0.03 ±1' ±2/5 .XXX±0.012			莱尔微波 Lair Microwave www.lairmw.com sales@lairmw.com		P/N: LPD2N-DC-6		
			Approvals	DATE	DC – 6000 MHz 功分/合路器 Power Splitter/Combiner		
HOLE DIAMETER .35 TO 3.20 3.21 TO 6.35 6.36 TO 12.70 12.71 TO 19.05 19.06 TO 25.40 25.41 TO 50.80	TOLERANCES +.05/- .02 +.10/- .03 +.15/- .03 +.20/- .03 +.25/- .03 +.30/- .03	DRWN		SIZE A3	CAGE NO	DWG NO.	REV 1
		ENG		SCALE 3:2	UNIT mm	SHEET 1 OF 1	
		CHK					
		Q.A.					