

NOTES:UNLESS OTHERWISE SPECIFIED
THIS IS A CAD GENERATED DRAWING,DO NOT REVISE MANUALLY

REVISION HISTORY					
ZONE	REV	DESCRIPTION	E.C.O.NO	DATE	APPROVED
	1	ENGINEERING RELEASE			

LMA-2014

5 – 13 GHz 有源三倍频器 Active Frequency Tripler

—电气技术参数 Electrical Specifications—

输入频率范围 Input Frequency Range:	5 – 13GHz
输出频率范围 Output Frequency Range:	15 – 39GHz
输入功率 Input Power:	-3~+3dBm
输出功率 Output Power:	17dBm
谐波抑制 F0 Harmonic Suppression F0:	/
输入驻波比 Input VSWR:	1.4:1
输出驻波比 Output VSWR:	1.5:1
直流偏置电压 DC Power Supply:	+9~+15V
直流偏置电流 DC Current Supply:	300mA
工作温度 Operation Temperature:	-40 ~ +40°C
存储温度 Storage Temperature:	-65 ~ +125°

—机械技术参数 Mechanical Specifications—

输入连接器 Input Interface:	SMA-F
输出连接器 Output Interface:	2.92mm-F
尺寸 Size (excluding connectors):	50x32x12mm
重量 Weight:	30g

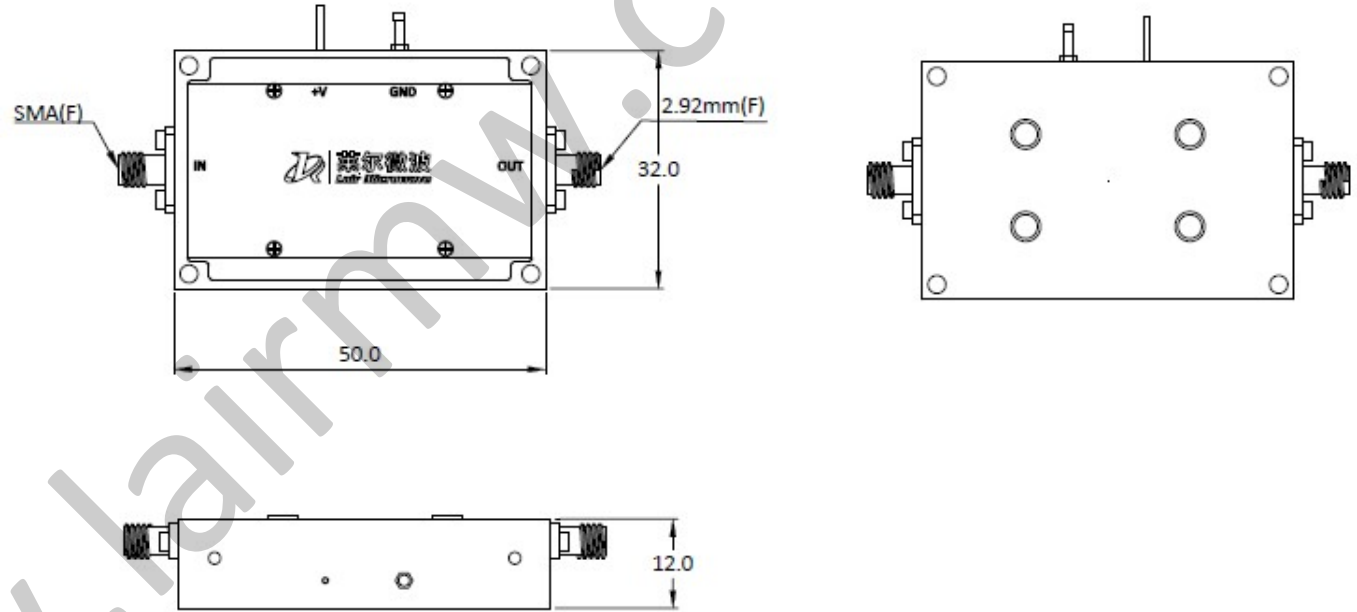

UNLESS OTHERWISE SPECIFIED DIMENSIONS ARE MILLIMETER TOLERANCES ARE: DECIMALS ANGLES FRACTIONS .XX±0.03 ±1' ±2/5 .XXX±0.012			 www.lairmw.com sales@lairmw.com	P/N: LMA-2014													
	Approvals	DATE		5 – 13 GHz Active Frequency Tripler													
HOLE DIAMETER .35 TO 3.20 3.21 TO 6.35 6.36 TO 12.70 12.71 TO 19.05 19.06 TO 25.40 25.41 TO 50.80	TOLERANCES +.05/- .02 +.10/- .03 +.15/- .03 +.20/- .03 +.25/- .03 +.30/- .03	DRWN	ENG	CHK	Q.A.												
<table border="1"> <tr> <td>SIZE</td> <td>A3</td> <td>CAGE NO</td> <td>DWG NO.</td> <td>REV</td> <td>1</td> </tr> </table>			SIZE	A3	CAGE NO	DWG NO.	REV	1	<table border="1"> <tr> <td>SCALE</td> <td>3:2</td> <td>UNIT</td> <td>mm</td> <td colspan="2">SHEET 1 OF 1</td> </tr> </table>			SCALE	3:2	UNIT	mm	SHEET 1 OF 1	
SIZE	A3	CAGE NO	DWG NO.	REV	1												
SCALE	3:2	UNIT	mm	SHEET 1 OF 1													