

NOTES:UNLESS OTHERWISE SPECIFIED  
THIS IS A CAD GENERATED DRAWING,DO NOT REVISE MANUALLY

| REVISION HISTORY |     |                     |          |      |          |
|------------------|-----|---------------------|----------|------|----------|
| ZONE             | REV | DESCRIPTION         | E.C.O.NO | DATE | APPROVED |
|                  | 1   | ENGINEERING RELEASE |          |      |          |

### Truth Table

| TTL | J1-J2 | J2-J3 |
|-----|-------|-------|
| "0" | ON    | OFF   |
| "1" | OFF   | ON    |

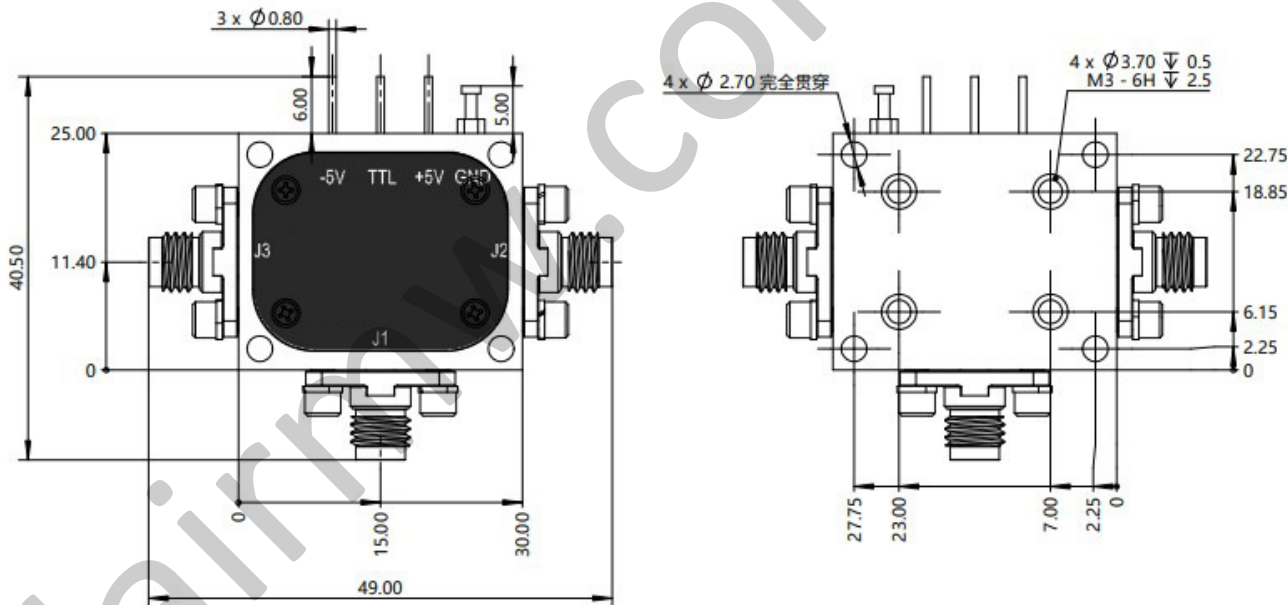
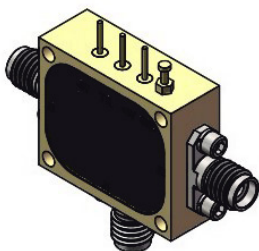

## LES-2009

12 - 18GHz PIN反射式单刀双掷开关 PIN Reflection SPDT Switch

### —电气技术参数Electrical Specifications—

|                             |              |
|-----------------------------|--------------|
| 频率范围 Frequency Range:       | 12 - 18GHz   |
| 隔离度 Isolation:              | 70dB(Typ.)   |
| 插入损耗 Insertion Loss:        | 3.0 - 4.0dB  |
| 驻波 VSWR:                    | 1.7:1(Typ.)  |
| 开关速度 Switching Speed:       | 100ns        |
| 最大输入功率 Maximum Input Power: | +23dBm       |
| 控制方式 Control Mode:          | TTL(详见真值表)   |
| 直流偏置电压 DC Supply Voltage:   | ±5V          |
| 直流偏置电流 DC Supply Current:   | 20mA(Max)    |
| 工作温度 Operation Temperature: | -40 ~ +85°C  |
| 存储温度 Storage Temperature:   | -65 ~ +125°C |

### —机械技术参数Mechanical Specification—

|                                |            |
|--------------------------------|------------|
| 输入连接器 Input Interface:         | SMA-F      |
| 输出连接器 Output Interface:        | SMA-F      |
| 尺寸 Size(excluding connectors): | 30x25x11mm |
| 重量 Weight:                     | 28.3g      |

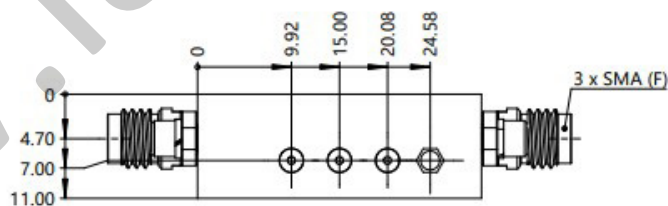

|  |  |  |  |   |  |   |  |
|--|--|--|--|---|--|---|--|
| UNLESS OTHERWISE SPECIFIED<br>DIMENSIONS ARE MILLIMETER<br>TOLERANCES ARE:<br>DECIMALS ANGLES FRACTIONS<br>.XX±0.03 ±1° ±2/5<br>.XXX±0.012 |  |  |  | 莱尔微波<br>Laird Microelectronics<br>www.lairmw.com sales@lairmw.com                     |  | P/N: LES-2009                                       |  |
| HOLE DIAMETER<br>.35 TO 3.20<br>3.21 TO 6.35<br>6.36 TO 12.70<br>12.71 TO 19.05<br>19.06 TO 25.40<br>25.41 TO 50.80                        |  | TOLERANCES<br>+.05/- .02<br>+.10/- .03<br>+.15/- .03<br>+.20/- .03<br>+.25/- .03<br>+.30/- .03 |  | Approvals: _____ DATE: _____<br>DRWN: _____<br>ENG: _____<br>CHK: _____<br>Q.A: _____ |  | 12-18GHz PIN吸收式单刀双掷开关<br>PIN Reflection SPDT Switch |  |
| SIZE A3  |  | CAGE NO  |  | DWG NO.   |  | REV 1   |  |
| SCALE 3:2  |  | UNIT mm  |  | SHEET 1 OF 1  |  |   |  |