

NOTES:UNLESSOTHERWISE SPECIFIED  
THIS IS A CAD GENERATED DRAWING,DO NOT REVISE MANUALLY

REVISION HISTORY					
ZONE	REV	DESCRIPTION	E.C.O.NO	DATE	APPROVED
	1	ENGINEERING RELEASE			

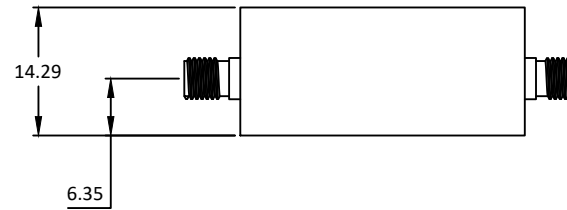
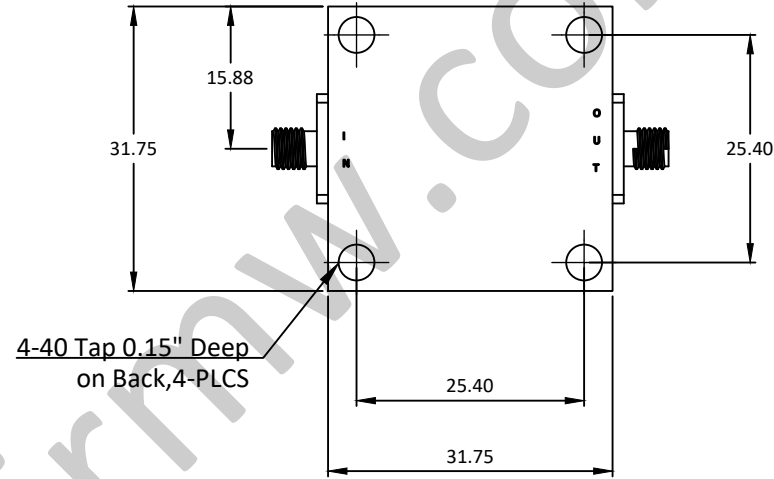
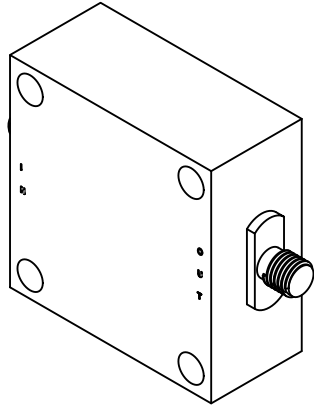

## LBF-5012

500 - 800MHz 带通滤波器 Band Pass Filter

—电气技术参数Electrical Specifications—

通带 Pass Band:	500-800MHz
中心频率Center Frequency:	650MHz
插入损耗Insertion Loss:	2dB
带外抑制Rejection:	40dB@300MHz/30dB@1000MHz
最大输入功率Maximum Input Power:	8W
群时延Group Delay:	2.5ns
输入驻波比Input VSWR:	2.0:1
输出驻波比Output VSWR:	2.0:1
工作温度Operation Temperature:	-30 ~ +85℃
存储温度Storage Temperature:	-40 ~ +100℃

—机械技术参数Mechanical Specification—

输入连接器Input Interface:	SMA-F
输出连接器Output Interface:	SMA-F
尺寸Size(excluding connectors):	31.75*31.75*14.29mm
重量Weight:	/

UNLESS OTHERWISE SPECIFIED DIMENSIONS ARE MILLIMETER TOLERANCES ARE: DECIMALS ANGLES FRACTIONS .X±0.1 ±1' ±2/5 .XX±0.03 .XXX±0.012			 www.lairmw.com sales@lairmw.com	P/N: LBF-5012	
	Approvals	DATE		500-800MHz 带通滤波器Band Pass Filter	
HOLE DIAMETER .35 TO 3.20 3.21 TO 6.35 6.36 TO 12.70 12.71 TO 19.05 19.06 TO 25.40 25.41 TO 50.80	TOLERANCES +.05/- .02 +.10/- .03 +.15/- .03 +.20/- .03 +.25/- .03 +.30/- .03	DRWN	ENG	CHK	Q.A.
SIZE A3			CAGE NO	DWG NO.	REV 1
SCALE 3:2			UNIT mm	SHEET 1 OF 1	