

NOTES: UNLESS OTHERWISE SPECIFIED
THIS IS A CAD GENERATED DRAWING, DO NOT REVISE MANUALLY

REVISION HISTORY					
ZONE	REV	DESCRIPTION	E.C.O.NO	DATE	APPROVED
	1	ENGINEERING RELEASE			

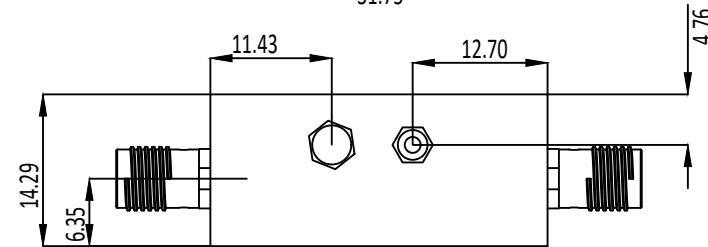

LAL-5142

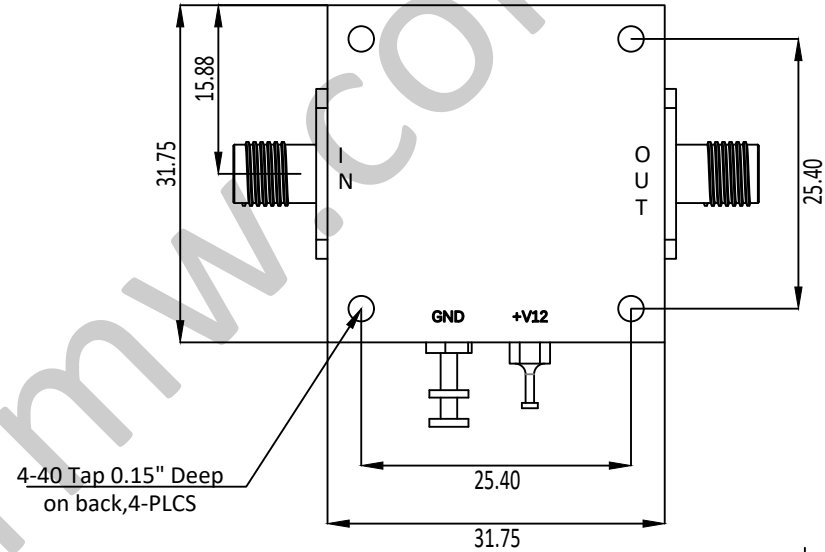
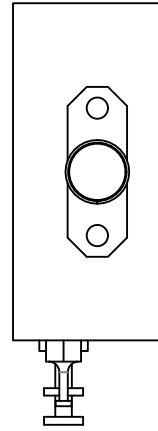
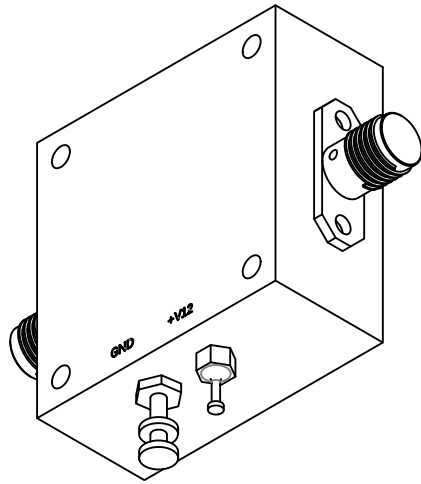

0.03 - 0.93 GHz 低噪声放大器 Low Noise Amplifier

—电气技术参数 Electrical Specifications—

频率范围 Frequency Range:	0.03 - 0.93 GHz
增益 Gain:	30dB
增益平坦度 Gain Flatness:	±0.5dB
噪声系数 Noise Figure:	1.5dB
输出 P_{1dB} Output P_{1dB} :	19dBm
输入驻波比 Input VSWR:	1.3:1
输出驻波比 Output VSWR:	1.1:1
直流偏置电压 DC Supply Voltage:	+12V
直流偏置电流 DC Supply Current:	115mA
工作温度 Operation Temperature:	-40~+85°C
存储温度 Storage Temperature:	-55~+125°C

—机械技术参数 Mechanical Specification—

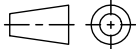
输入连接器 Input Interface:	SMA-F
输出连接器 Output Interface:	SMA-F
尺寸 Size(excluding connectors):	/
重量 Weight:	/

UNLESS OTHERWISE SPECIFIED DIMENSIONS ARE MILLIMETER TOLERANCES ARE: DECIMALS ANGLES FRACTIONS .XX±0.03 ±1' ±2/5 .XXX±0.012		 Approvals DATE		 www.lairmw.com sales@lairmw.com		P/N: LAL-5142	
HOLE DIAMETER .35 TO 3.20 3.21 TO 6.35 6.36 TO 12.70 12.71 TO 19.05 19.06 TO 25.40 25.41 TO 50.80		TOLERANCES +.05/-02 +.10/-03 +.15/-03 +.20/-03 +.25/-03 +.30/-03		DRWN ENG CHK Q.A.		0.03 - 0.93 GHz 低噪声放大器 Low Noise Amplifier 增益 Gain 30dB, 噪声系数 NF 1.5dB	
SIZE A3		CAGE NO		DWG NO.		REV 1	
SCALE 3:2		UNIT mm		SHEET 1 OF 1			