

NOTES:UNLESS OTHERWISE SPECIFIED
THIS IS A CAD GENERATED DRAWING,DO NOT REVISE MANUALLY

REVISION HISTORY					
ZONE	REV	DESCRIPTION	E.C.O.NO	DATE	APPROVED
	1	ENGINEERING RELEASE			

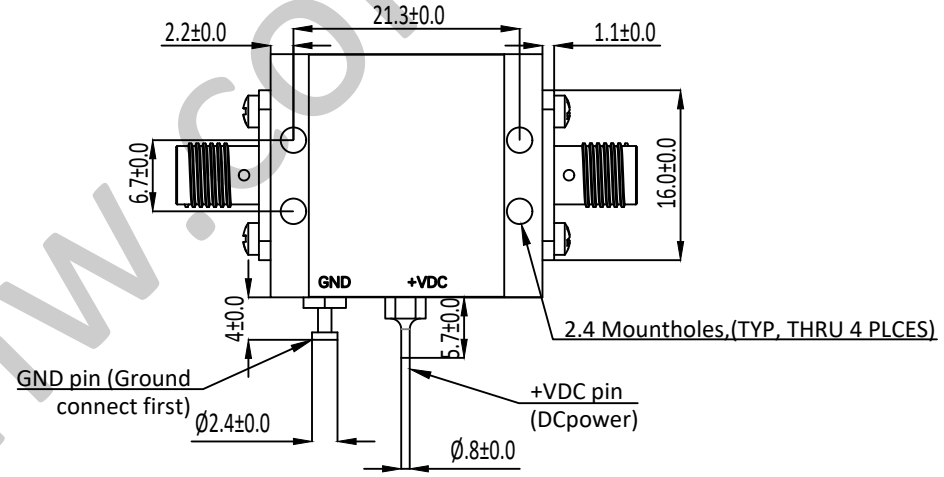
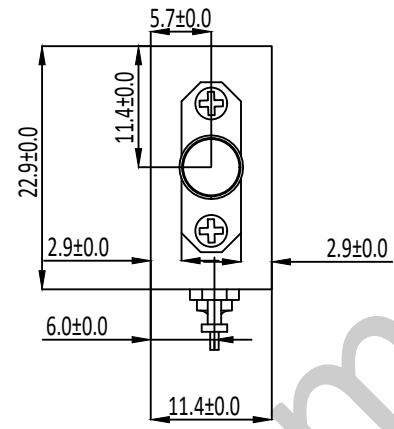
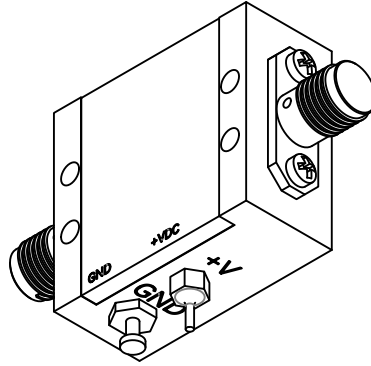

LAL-5112

0.01 - 8GHz 低噪声放大器 Low Noise Amplifier



—电气技术参数 Electrical Specifications—

频率范围 Frequency Range:	0.01 - 8GHz
增益 Gain:	40dB
增益平坦度 Gain Flatness:	±1.5dB
噪声系数 Noise Figure:	2.0dB
输出 P_{1dB} Output P_{1dB} :	20dBm
输入驻波比 Input VSWR:	1.8:1
输出驻波比 Output VSWR:	2.5:1
直流偏置电压 DC Supply Voltage:	+12V
直流偏置电流 DC Supply Current:	160mA
工作温度 Operation Temperature:	-40~+85°C
存储温度 Storage Temperature:	-55~+125°C

—机械技术参数 Mechanical Specification—

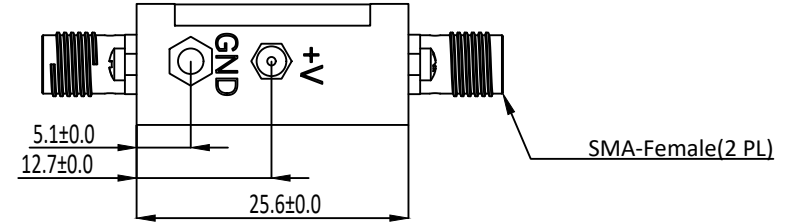
输入连接器 Input Interface:	SMA-F
输出连接器 Output Interface:	SMA-F
尺寸 Size(excluding connectors):	/
重量 Weight:	/

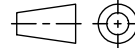

UNLESS OTHERWISE SPECIFIED DIMENSIONS ARE MILLIMETER TOLERANCES ARE: DECIMALS ANGLES FRACTIONS .X±0.1 ±1' ±2/5 .XX±0.03 .XXX±0.012		 Approvals DATE		 www.lairmw.com sales@lairmw.com		P/N: LAL-5112	
						0.01-8GHz 低噪声放大器 Low Noise Amplifier 增益 Gain 40dB, 噪声系数 NF 2.0dB	
HOLE DIAMETER .35 TO 3.20 3.21 TO 6.35 6.36 TO 12.70 12.71 TO 19.05 19.06 TO 25.40 25.41 TO 50.80		TOLERANCES +.05/- .02 +.10/- .03 +.15/- .03 +.20/- .03 +.25/- .03 +.30/- .03		DRWN	ENG	CHK	Q.A.
				SIZE A3	CAGE NO	DWG NO.	REV 1
				SCALE 3:2	UNIT mm	SHEET 1 OF 1	