

NOTES: UNLESS OTHERWISE SPECIFIED
THIS IS A CAD GENERATED DRAWING, DO NOT REVISE MANUALLY

| REVISION HISTORY | | | | | |
|------------------|-----|---------------------|----------|------|----------|
| ZONE | REV | DESCRIPTION | E.C.O.NO | DATE | APPROVED |
| | 1 | ENGINEERING RELEASE | | | |

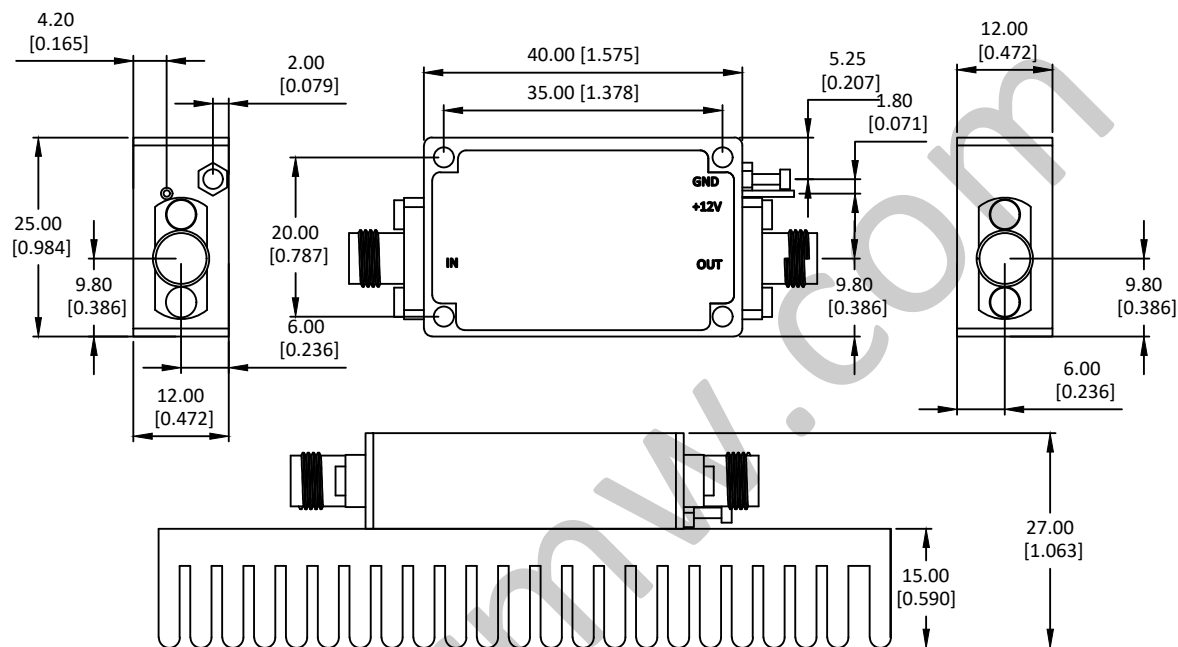
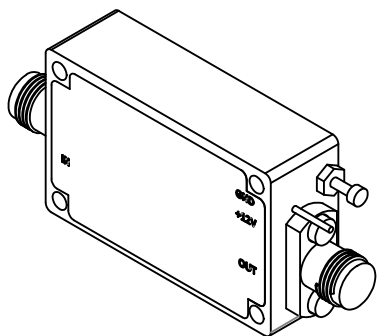

LAL-1152

0.01~3GHz 低噪声放大器 Low Noise Amplifier

—电气技术参数 Electrical Specifications—

| | |
|---|-------------|
| 频率范围 Frequency Range: | 0.01 - 3GHz |
| 增益 Gain: | 36B |
| 增益平坦度 Gain Flatness: | / |
| 噪声系数 Noise Figure: | 1.5dB |
| 输出 P _{1dB} Output P _{1dB} : | 21dBm |
| 输入驻波比 Input VSWR: | 1.8:1 |
| 输出驻波比 Output VSWR: | 1.8:1 |
| 直流偏置电压 DC Supply Voltage: | +12V |
| 直流偏置电流 DC Supply Current: | 220mA |
| 工作温度 Operation Temperature: | -40~+85°C |
| 存储温度 Storage Temperature: | -50~+105°C |

—机械技术参数 Mechanical Specification—

| | |
|---------------------------------|-------|
| 输入连接器 Input Interface: | SMA-F |
| 输出连接器 Output Interface: | SMA-F |
| 尺寸 Size (excluding connectors): | / |
| 重量 Weight: | / |

Including Heat sink

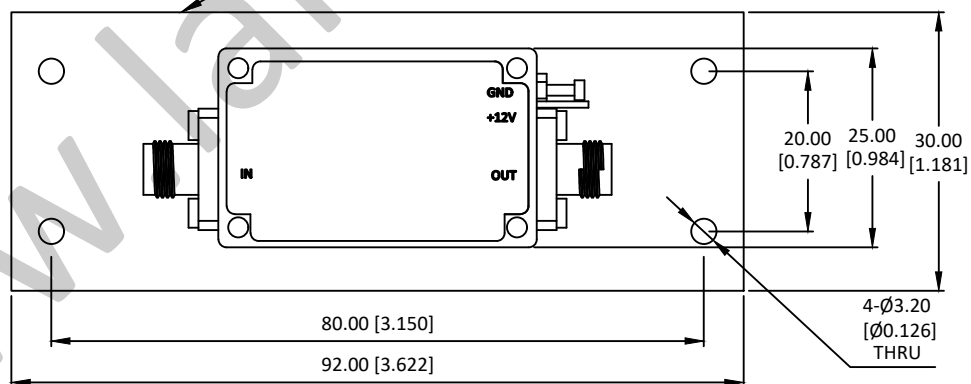

UNLESS OTHERWISE SPECIFIED
DIMENSIONS ARE MILLIMETER
TOLERANCES ARE:
DECIMALS ANGLES FRACTIONS
.XX±0.1 ±1' ±2/5
.XXX±0.012

| HOLE DIAMETER | TOLERANCES |
|----------------|-------------|
| 3.5 TO 3.20 | +0.05/-0.02 |
| 3.21 TO 6.35 | +0.10/-0.03 |
| 6.36 TO 12.70 | +0.15/-0.03 |
| 12.71 TO 19.05 | +0.20/-0.03 |
| 19.06 TO 25.40 | +0.25/-0.03 |
| 25.41 TO 50.80 | +0.30/-0.03 |

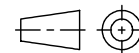

Approvals

DATE

DRWN

ENG

CHK

Q.A.



www.lairmw.com sales@lairmw.com

P/N: LAL-1152

0.01-3GHz 低噪声放大器 Low Noise Amplifier
增益 Gain 36dB, 噪声系数 NF 1.5dB

| SIZE | CAGE NO | DWG NO. | REV |
|-------|---------|--------------|-----|
| A3 | | | 1 |
| SCALE | UNIT | SHEET 1 OF 1 | |
| 3:2 | mm | | |