

NOTES: UNLESS OTHERWISE SPECIFIED  
THIS IS A CAD GENERATED DRAWING, DO NOT REVISE MANUALLY

| REVISION HISTORY |     |                     |          |      |          |
|------------------|-----|---------------------|----------|------|----------|
| ZONE             | REV | DESCRIPTION         | E.C.O.NO | DATE | APPROVED |
|                  | 1   | ENGINEERING RELEASE |          |      |          |

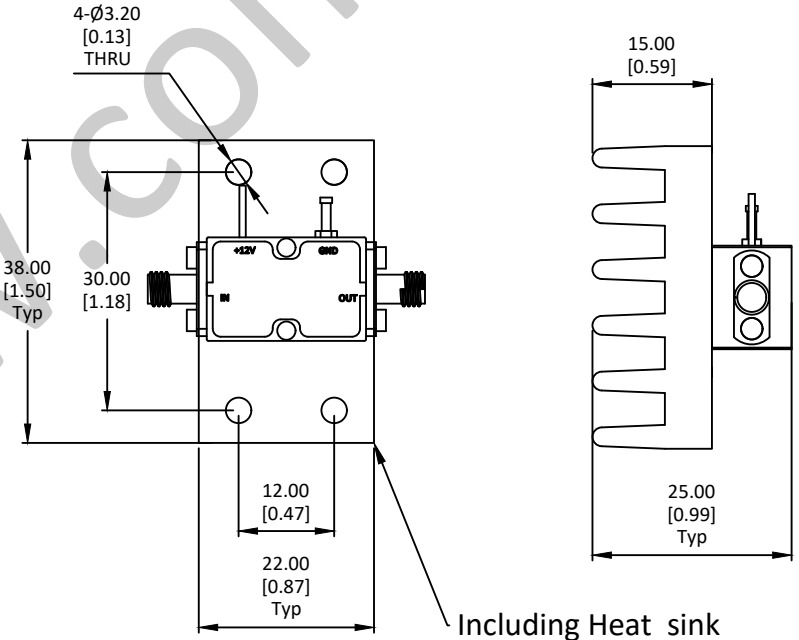
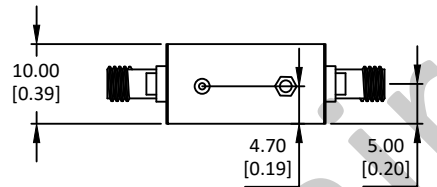
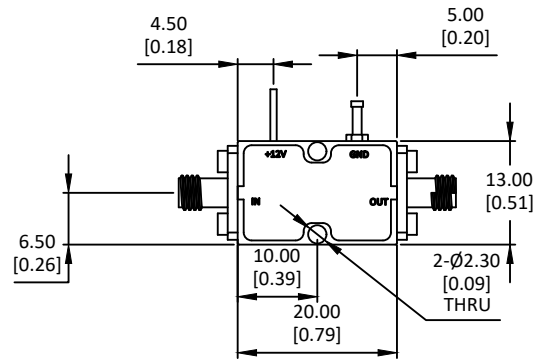
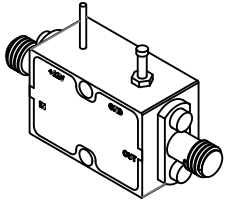

## LAL-1128

12~15GHz 低噪声放大器 Low Noise Amplifier

—电气技术参数 Electrical Specifications—

|                                 |            |
|---------------------------------|------------|
| 频率范围 Frequency Range:           | 12 - 15GHz |
| 增益 Gain:                        | 32dB       |
| 增益平坦度 Gain Flatness:            | /          |
| 噪声系数 Noise Figure:              | 1.7dB      |
| 输出 $P_{1dB}$ Output $P_{1dB}$ : | 19.5dBm    |
| 输入驻波比 Input VSWR:               | 1.7:1      |
| 输出驻波比 Output VSWR:              | 1.3:1      |
| 直流偏置电压 DC Supply Voltage:       | +12V       |
| 直流偏置电流 DC Supply Current:       | 200mA      |
| 工作温度 Operation Temperature:     | -40~+85°C  |
| 存储温度 Storage Temperature:       | -50~+105°C |

—机械技术参数 Mechanical Specification—

|                                 |       |
|---------------------------------|-------|
| 输入连接器 Input Interface:          | SMA-F |
| 输出连接器 Output Interface:         | SMA-F |
| 尺寸 Size (excluding connectors): | /     |
| 重量 Weight:                      | /     |

|  |  |      |  |  |          |
|--|--|------|--|--|----------|
| UNLESS OTHERWISE SPECIFIED<br>DIMENSIONS ARE MILLIMETER<br>TOLERANCES ARE:<br>DECIMALS ANGLES FRACTIONS<br>.XX±0.03 ±1° ±2/5<br>.XXX±0.012 |  |      | 莱尔微波<br>Laird Microwave<br>www.lairmw.com sales@lairmw.com | P/N: LAL-1128  |          |
|  | Approvals  | DATE |  | 12-15GHz 低噪声放大器 Low Noise Amplifier<br>增益 Gain 32dB, 噪声系数 NF 1.7dB |          |
| HOLE DIAMETER<br>.35 TO 3.20<br>3.21 TO 6.35<br>6.36 TO 12.70<br>12.71 TO 19.05<br>19.06 TO 25.40<br>25.41 TO 50.80                        | TOLERANCES<br>+.05/- .02<br>+.10/- .03<br>+.15/- .03<br>+.20/- .03<br>+.25/- .03<br>+.30/- .03 | DRWN | SIZE<br>A3   | CAGE NO  | DWG NO.  |
|  |  | ENG  | SCALE<br>3:2   | UNIT<br>mm   | REV<br>1 |
|  |  | CHK  | SHEET 1 OF 1   |  |          |
|  |  | Q.A. |  |  |          |