

NOTES: UNLESS OTHERWISE SPECIFIED
THIS IS A CAD GENERATED DRAWING, DO NOT REVISE MANUALLY

REVISION HISTORY					
ZONE	REV	DESCRIPTION	E.C.O.NO	DATE	APPROVED
	1	ENGINEERING RELEASE			

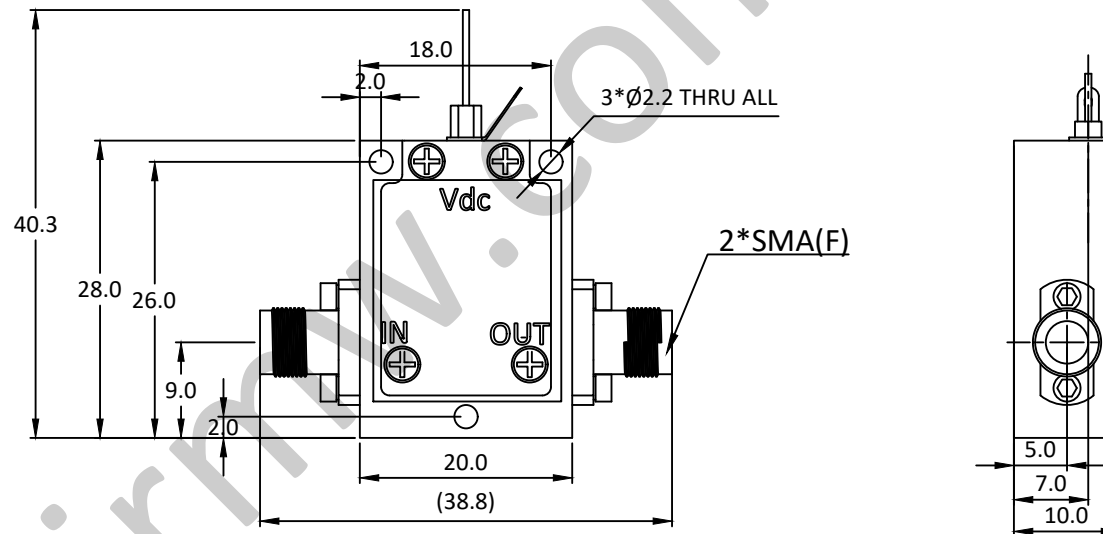
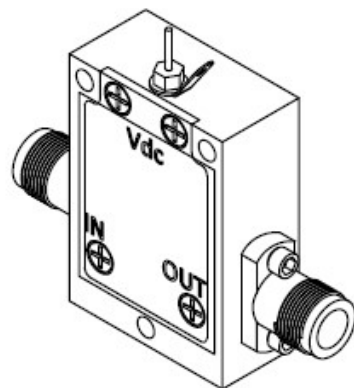

LAL-0003

9 - 10GHz 低噪声放大器 Low Noise Amplifier

—电气技术参数 Electrical Specifications—

频率范围 Frequency Range:	9-10GHz
增益 Gain:	21.5dB(Typ)
增益平坦度 Gain Flatness:	±0.5dB
噪声系数 Noise Figure:	1.5dB(Typ)
输出 P _{1dB} Output P _{1dB} :	19dBm(Typ)
饱和输出功率 P _{sat} :	21dBm(Typ)
最大输入功率 Maximum Input Power:	23dBm
输入驻波比 Input VSWR:	1.7:1
输出驻波比 Output VSWR:	1.4:1
直流偏置电压 DC Supply Voltage:	+5.5 ~ +15V
直流偏置电流 DC Supply Current:	160mA
工作温度 Operation Temperature:	-40 ~ +85°C
存储温度 Storage Temperature:	-65 ~ +125°C

—机械技术参数 Mechanical Specification—

输入连接器 Input Interface:	SMA-F
输出连接器 Output Interface:	SMA-F
尺寸 Size(excluding connectors):	20mm*28mm*10mm
重量 Weight:	20g

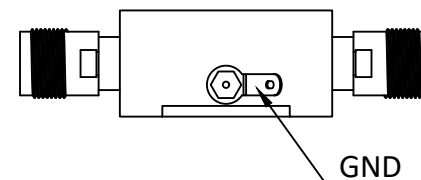

UNLESS OTHERWISE SPECIFIED DIMENSIONS ARE MILLIMETER TOLERANCES ARE: DECIMALS ANGLES FRACTIONS .X±0.1 ±1' ±2/5 .XX±0.03 .XXX±0.012						P/N: LAL-0003	
		Approvals		DATE		www.lairmw.com sales@lairmw.com	
HOLE DIAMETER .35 TO 3.20 3.21 TO 6.35 6.36 TO 12.70 12.71 TO 19.05 19.06 TO 25.40 25.41 TO 50.80		TOLERANCES +05/-02 +10/-03 +15/-03 +20/-03 +25/-03 +30/-03		DRWN ENG CHK Q.A.		9-10GHz 低噪声放大器 Low Noise Amplifier 增益 Gain 21.5dB, 噪声系数 NF 1.5dB	
				SIZE A3		CAGE NO	
				SCALE 3:2		UNIT mm	
						DWG NO.	
						REV 1	
						SHEET 1 OF 1	