

NOTES:UNLESSOTHERWISE SPECIFIED
THIS IS A CAD GENERATED DRAWING,DO NOT REVISE MANUALLY

REVISION HISTORY					
ZONE	REV	DESCRIPTION	E.C.O.NO	DATE	APPROVED
	1	ENGINEERING RELEASE			

13-L1600-200-2507

1500 - 1700 MHz 带通滤波器 Band Pass Filter



—电气技术参数 Electrical Specifications—

通带频率 Pass Band Frequency:	1500 – 1700 MHz
中心损耗 Loss:	3.0dB
带内波动 In-band Fluctuation:	1.0dB
带外抑制 Rejection:	60dB@DC-1.3GHz 60dB@1.9-4GHz (Min.)
通带驻波比 Pass Band VSWR:	1.8:1 (Max.)
功率容量 Power:	2W
工作温度 Operation Temperature:	-40 ~ +70°C
存储温度 Storage Temperature:	-50 ~ +85°C

—机械技术参数 Mechanical Specifications—

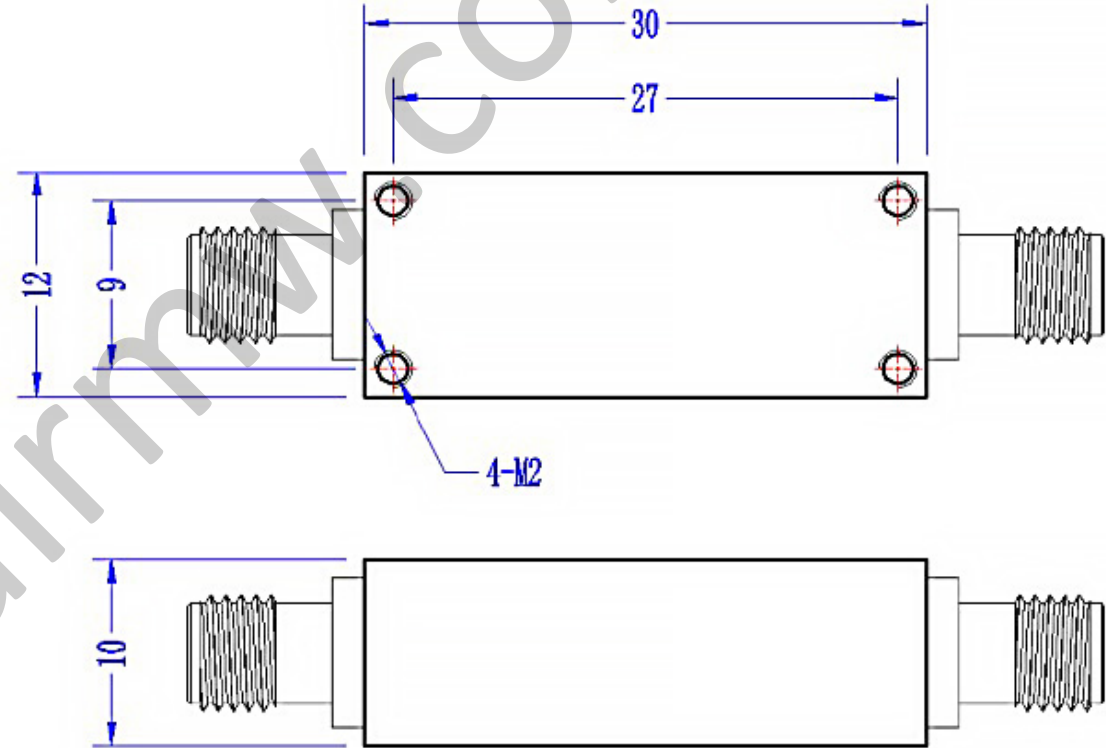
输入连接器 Input Interface:	SMA-K
输出连接器 Output Interface:	SMA-K

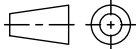

UNLESS OTHERWISE SPECIFIED DIMENSIONS ARE MILLIMETER TOLERANCES ARE: DECIMALS ANGLES FRACTIONS .XX±0.03 ±1' ±2/5 .XXX±0.012				 www.lairmw.com sales@lairmw.com		P/N: 13-L1600-200-2507	
APPROVALS: _____ DATE: _____ DRWN: _____ ENG: _____ CHK: _____ Q.A.: _____		1500-1700MHz 带通滤波器 Band Pass Filter					
HOLE DIAMETER .35 TO 3.20 3.21 TO 6.35 6.36 TO 12.70 12.71 TO 19.05 19.06 TO 25.40 25.41 TO 50.80		TOLERANCES +.05/-02 +.10/-03 +.15/-03 +.20/-03 +.25/-03 +.30/-03		SIZE A3	CAGE NO	DWG NO.	REV 1
		SCALE 3:2	UNIT mm	SHEET 1 OF 1			